

(No Model.)

3 Sheets—Sheet 1.

L. H. BRIGHTMAN.
SHAFT TURNING MACHINE.

No. 456,882.

Patented July 28, 1891.

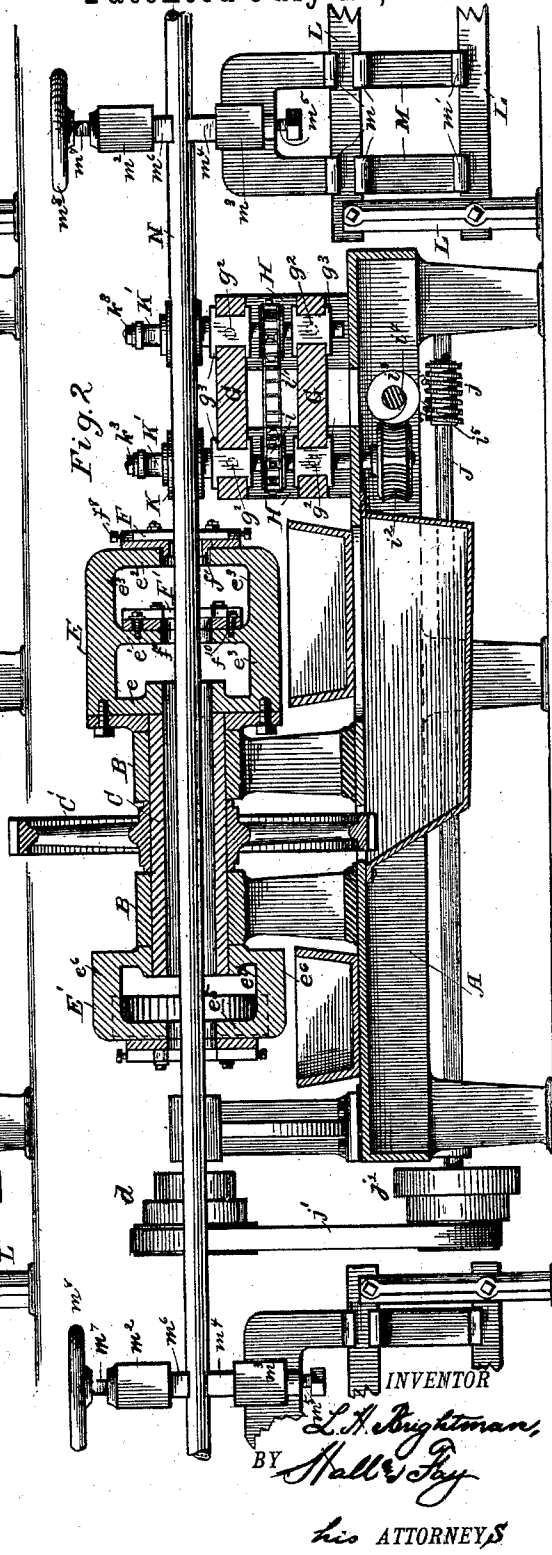
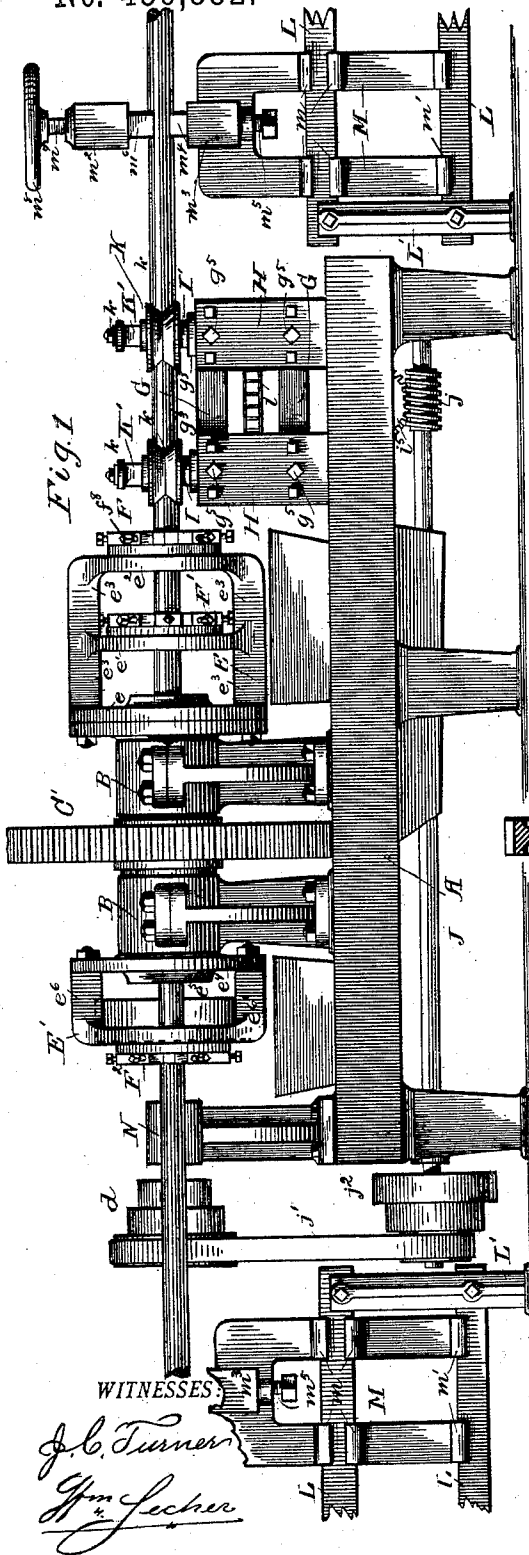

(No Model.)

3 Sheets—Sheet 2.

L. H. BRIGHTMAN.
SHAFT TURNING MACHINE.

No. 456,882.

Patented July 28, 1891.

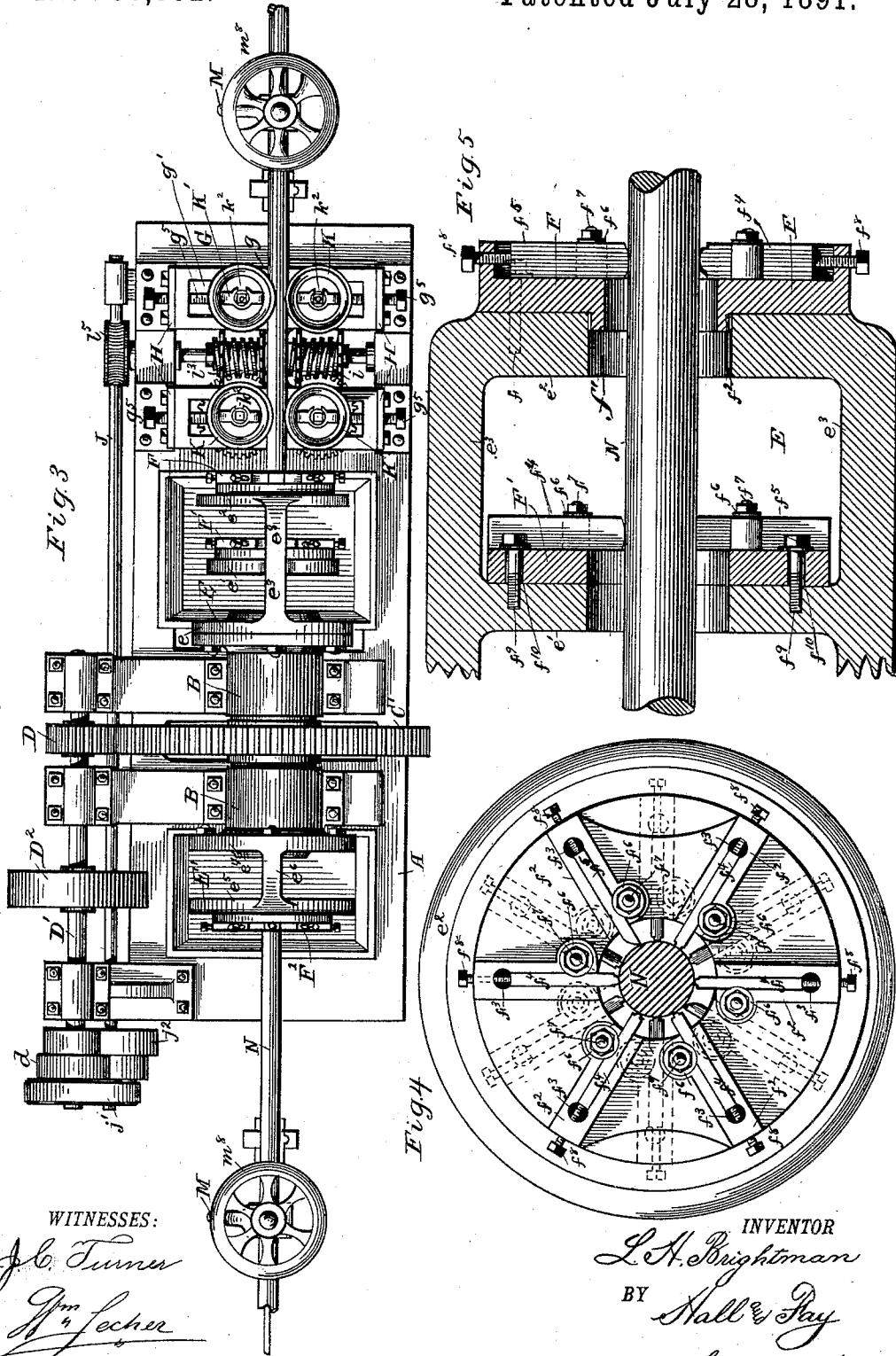

WITNESSES:
J. C. Turner
John Lecher

INVENTOR
L. H. Brightman
 BY *Hall & Day*
 his ATTORNEYS

THE NORRIS PETERS CO., PHOTO-LITHO., WASHINGTON, D. C.

L. H. BRIGHTMAN.
SHAFT TURNING MACHINE.

No. 456,882.

Patented July 28, 1891.

Fig. 6

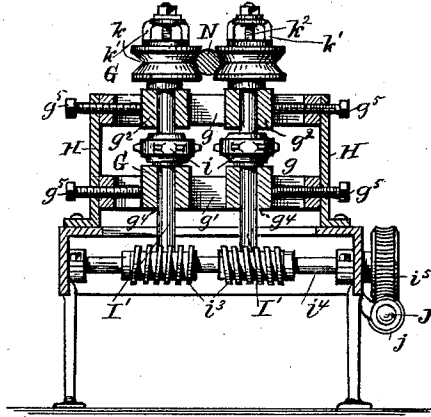

Fig. 7

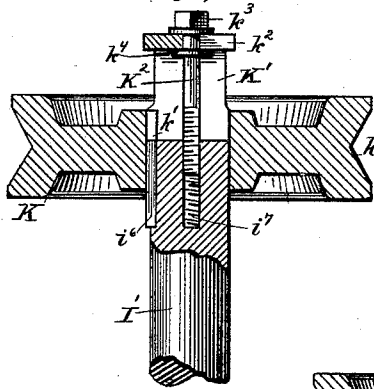

Fig. 9

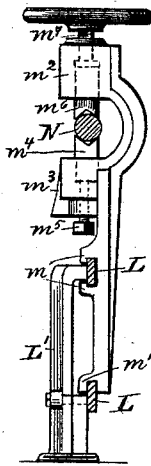
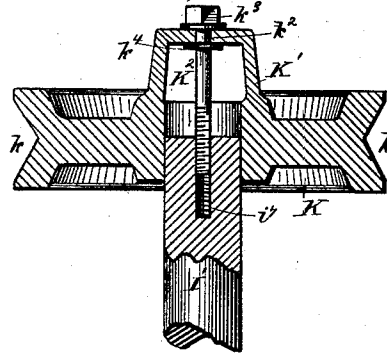

Fig. 8



WITNESSES:

J. C. Turner
Wm. Lecher

INVENTOR

L. H. Brightman
BY *Hall & Day*
his ATTORNEYS

UNITED STATES PATENT OFFICE.

LATHAM H. BRIGHTMAN, OF CLEVELAND, OHIO, ASSIGNOR TO THE
BRIGHTMAN MACHINE COMPANY, OF SAME PLACE.

SHAFT-TURNING MACHINE.

SPECIFICATION forming part of Letters Patent No. 456,882, dated July 28, 1891.

Application filed February 6, 1891. Serial No. 380,465. (No model.)

To all whom it may concern:

Be it known that I, LATHAM H. BRIGHTMAN, a citizen of the United States, and a resident of Cleveland, county of Cuyahoga, and State of Ohio, have invented certain new and useful Improvements in Shaft-Turning Machines, of which the following is a specification, the principle of the invention being herein explained and the best mode in which I have contemplated applying that principle so as to distinguish it from other inventions.

The objects of my invention are to provide improved means for rough-turning and finishing the work at one operation in a machine for turning shafts and other cylindrical objects of metal having rotary heads; to provide improved means for evenly turning curved or crooked portions of the work; to provide improved means for supporting the work in the rotary heads; to provide improved means for adjusting the feeding-rollers for the work; to provide improved means for adjustably securing the cutters and steady-rests in the revolving heads, and to provide an efficient and compact machine for turning shafts or other cylindrical objects in such a manner that they will require but little finishing or smoothing after leaving the machine.

In the accompanying drawings, Figure 1 represents a side elevation of my improved shaft-turning machine; Fig. 2, a longitudinal vertical section of the same; Fig. 3, a top plan view; Fig. 4, a front view of one of the cutting and supporting heads; Fig. 5, an axial section of the double yoke and its heads; Fig. 6 a transverse vertical section of the shaft-feeding mechanism; Figs. 7 and 8, axial sections, taken at right angles, of one of the shaft-feeding rollers and its shaft; and Fig. 9, an end view of one of the shaft-supporting clamps, showing the guides for the same in vertical cross-section.

In said drawings, the letter A indicates the bed or main frame of the machine, upon the middle of which are supported two longitudinal bearings B B, in which a tubular spindle C is journaled. Said spindle has a cog-wheel C' secured upon it, which meshes with a pinion D upon the power-shaft D', which is re-

volvied by a belt passing around the power-pulleys D² upon said shaft or by other suitable gearing. A double yoke E is secured upon one end of said spindle and a single yoke E' is secured upon the other end of the spindle. The double yoke E is composed of three annular disks or rings e, e', and e², the inner one e of which is secured to the end of the tubular spindle, while the outer disks e' and e² are separated from and connected to the inner disk and each other by means of short arms e³, projecting diametrically opposite to each other from the faces of the inner and intermediate disks e and e'. The single yoke E' is composed of two annular disks e⁴ and e⁵, the inner one e⁴ of which is secured to the rear end of the tubular spindle, while the outer disk e⁵ is supported from said inner disk by two diametrically-opposite projecting arms e⁶. A disk or head F for rough-turning the shaft is secured upon the outer disk e² by means of bolts f, and has an annular flange f', which fits into the central opening of said outer disk. Said head is formed with a number of radiating ribs f² upon its outer face, which have radiating grooves f³, of the same depth as the ribs. Steady-rests f⁴, which are formed by flat metal bars, are placed in all but one of said grooves, and a cutting-tool f⁵ is placed in the remaining groove. The steady-rests and the cutting-tool are confined in the grooves by washers f⁶ upon screw-bolts f⁷, which enter the faces of the ribs and force the washers, which overlap the faces of the steady-rests and cutting-tool, against the same. Screw-bolts f⁸ pass through the outer ends of the ribs into the grooves, and bear against the outer ends of the steady-rests and cutting-tool, serving to adjust the same against the shaft to be turned, said steady-rests being adjusted to just bear against the shaft, and said cutting-tool being adjusted to rough-turn or cut the shaft. A similar disk or head F' is secured upon the intermediate disk e' and has ribs f², grooves f³, washers and bolts f⁶ f⁷ f⁸, steady-rests f⁴, and a cutter f⁵ exactly similar to the outer head, but has no flange at its central opening. Said head is secured to the face of the intermediate disk by means of screw-bolts f⁹, which pass into the disk through holes f¹⁰ in

the head, of a greater diameter than said bolts, so that the head may have a moderate degree of play upon the disk. Another similar disk or head f^2 of exactly the same construction as the head F is secured upon the disk e^5 of the yoke E', and has steady-rests and a cutting-tool similar to the steady-rests and cutting-tools of the outer heads.

Two H-shaped frames G are transversely secured with the ends of their longitudinally-slotted bars g to upright plates H upon the bed-frame, and have slots g' in their bars g longitudinal to the bars and transverse to the frame. Two pairs of blocks g^2 , having flanges g^3 overlapping the edges of the slots, slide in said slots, have vertical bearings g^4 , and may be adjusted in the slots by means of adjusting-screws g^5 bearing against them and inserted through the ends of the slotted bars.

Vertical shafts I' are journaled in the bearing-blocks g^2 g^4 , and are provided with sprocket-wheels i upon their middles at points between the H-shaped frames. Two sprocket-chains i' pass each around one pair of sprocket-wheels, connecting the shafts at each side of the machine, and one shaft of each pair has a worm-wheel i^2 upon its lower end, which is engaged by one of two right and left handed worms i^3 upon a worm-shaft i^4 , transversely journaled in the bed-frame beneath the H-shaped frames. A worm-wheel i^5 is secured upon the end of said worm-shaft and is engaged by a worm j upon a shaft J, longitudinally journaled upon the side of the bed-frame and revolved from the power-shaft by a belt j' , passed around one step of a cone-pulley j^2 upon the longitudinal worm-shaft and one step of a cone-pulley d upon the power-shaft.

The upper ends of the vertical shafts I' have feathers, keys, or splines i^6 and axial screw-threaded bores i^7 , and the feed rollers or wheels K, having V-shaped or round peripheral grooves k , fit and are vertically movable upon said upper ends, having grooves k' in their central bores to fit upon said feathers. The feed-rollers are formed with yokes K', which straddle over the central bores and the ends of the shafts, and said yokes have holes k^2 in their upper ends, open at one side, in which holes screw-bolts K^2 fit and turn, having heads k^3 upon their upper ends and collars k^4 below said heads, and having their screw-threaded ends fitting and turning in the screw-threaded axial bores of the shafts. Said bolts fit in the holes of the yokes with their heads above and their collars below the same, so that they may revolve in said holes and adjust the rollers up and down upon the shafts, and the open sides of the holes in the yokes admit of the bolts being freely and easily inserted or removed.

Longitudinal guide-rails L are supported at both ends of the bed-frame in the axial plane of the spindle, and turning heads upon suitable upright brackets L' and clamp-frames M, having two pairs of oppositely-pro-

jecting lips or flanges m , which slide upon the upper guide-rail, and foot-flanges m' , which slide upon the lower rail, may be longitudinally slid upon said guide-rails. The upper portions of said frames are formed with two vertically-opposite sockets m^2 and m^3 , in the lower one m^3 of which a jaw m^4 , having a V-shaped notch, is adjusted by means of a screw m^5 , inserted through the bottom of said socket. A similarly V-shape-notched jaw m^6 is inserted in the upper socket and is vertically adjusted by a screw m^7 and hand-wheel m^8 .

In practice the round bar or shaft N is secured in the sliding clamp-frame M at the forward end of the machine and is inserted between the feed-rollers. The jaws of the clamp-frame have been so adjusted by means of their adjusting-screws as to exactly center the shaft in the cutter-heads and in the spindle. The feed-rollers have also been so adjusted vertically by means of the screws K^2 and yokes K', and horizontally by means of the screws g^5 , that the shaft will be centered to the cutters and will be firmly gripped by them. When now the machine is started, the feed-rollers will feed the shaft into the first head, which will rough-turn it, the cutter being adjusted to just remove the most prominent irregularities. The shaft then passes to the second head, the cutter of which is so adjusted as to nearly finish the shaft, and which has sufficient play by means of its enlarged bolt-holes f^{10} to yield to and follow any curves existing in the shaft, so that the shaft will be turned round in relation to its axis, regardless of curvatures in the same. From the second head the shaft passes to the finishing-head at the rear end of the spindle, which will turn the shaft smooth, ready for the straightening and polishing machine. After leaving the rear cutter-head the shaft is supported by the rear sliding clamp-frame M, so that the shaft will be firmly and truly centrally supported. The feed of the shaft may be regulated by shifting the belt j' upon the cone-pulleys, and on account of the feed-rollers having V-shaped or rounded grooves and being laterally adjustable the machine may turn shafts of any diameter within the capacity of the machine.

As the cutters and steady-rests are secured in grooves in the heads, open in front, it is obvious that repairs of said cutters and steady-rests may take place without removing the heads; but by simply unscrewing the screw-bolt which holds the washer against the cutter or steady-rest to be removed said part may be removed, another put in its place, and the screw-bolt and washer again forced against it.

In this machine the shaft will be rough-turned and finished in one operation, ready for the straightening and smoothing or polishing machine, and will be turned into a truly-cylindrical shape around its true axis without regard to curvatures which may exist in the shaft. This is accomplished by having

the inner or intermediate head yielding or universally movable to a limited extent in a plane transverse to the axis of the shaft to be turned and could not be accomplished by a machine having rigid heads, as in such machine the cutter would remove material from the convex sides of the curvatures and thus leave the shafts irregular in cross-sections.

The foregoing description and accompanying drawings set forth in detail mechanism embodying my invention. Change may be made therein provided the principles of construction respectively recited in the following claims are employed.

I therefore particularly point out and distinctly claim as my invention—

1. In a shaft-turning machine, the combination, with a revolving lathe-head, of a cutter-head loosely secured upon one face of said lathe-head self-adjustable in the plane of said face, substantially as set forth.

2. In a shaft-turning machine, the combination, with a revolving lathe-head, of a plurality of cutter-heads upon the same, one of said cutter-heads being self-adjustable in a plane at right angles to the axis of the lathe-head, substantially as set forth.

3. In a shaft-turning machine, the combination, with a revolving annular disk, of a cutter-head upon the face of said disk formed with enlarged bolt-holes, and screw-bolts of less diameter than said holes inserted through said holes into said disk, substantially as set forth.

4. In a shaft-turning machine, the combination, with three revolving annular disks arranged in axial alignment, of cutter-heads rigidly secured to the two outer heads, and a

cutter-head secured to the middle disk having limited universal play upon the face of the same, substantially as set forth.

5. In a shaft-turning machine, the combination, with three revolving annular disks arranged in axial alignment, of cutter-heads secured to the two outer disks, a cutter-head upon the middle disk having bolt-holes formed in it, and screw-bolts of less diameter than said holes inserted through said holes into said middle disk, substantially as set forth.

6. In a shaft-turning machine, the combination, with a vertical feed-roller shaft having an axial screw-threaded bore in its upper end, of a feed-roller sliding upon and turning with said shaft and provided with a yoke straddling the end of said shaft, and a screw turning in said yoke and fitting in the axial bore of the shaft, substantially as set forth.

7. In a shaft-turning machine, the combination, with a vertical feed-roller shaft provided with a feather and with an axial bore in its upper end, of a feed-roller sliding upon said shaft and feather and formed with a yoke straddling the upper end of the shaft and having a hole in its upper end open at one side, and a screw-bolt in said hole and in the screw-threaded bore of the shaft and having a head and a collar respectively above and below said hole, substantially as set forth.

In testimony that I claim the foregoing to be my invention I have hereto set my hand this 23d day of December, A. D. 1890.

LATHAM H. BRIGHTMAN.

Witnesses:

J. B. FAY,
WM. SECHER.